

# SKX-1000D

## SPO2 Simulator



## Operation manual

Version: V 2.1

Xuzhou Mingsheng electronic Technology Co., LTD

# Catalogue

Chapter 1 SKX-1000D instrument features and functions .....	3
Chapter 2 Precautions for SKX-1000D instrument use .....	6
Chapter 3 SKX-1000D instrument connection description .....	7
Chapter 4 Describes the SKX-1000D display contents .....	9
Chapter 5 SKX-1000D key description .....	11
Chapter 6 Describes SKX-1000D parameter performance .....	12
Chapter 7 SKX-1000D after-sales service .....	13
Appendix 1	
Weak perfusion characteristics of blood oxygen .....	14
About the detection method of simulated blood oxygen .....	16

## Chapter 1 SKX-1000D instrument features and functions

SKX-1000D SPO2 Simulator is a signal simulation tool for the development and detection of blood oxygen saturation products developed by Xuzhou Mingsheng Company. Because it can produce different curves, different pulse amplitude of the analog optical signal, is the necessary first choice for the development of measurement of blood oxygen products, it has a wide range of signal amplitude, can simulate a variety of intensity, frequency of blood oxygen signals, is an important tool for the development of measurement of blood oxygen products. The simulator also has the function of detecting blood oxygen measurement products, and is used to test whether the parameters of blood oxygen products can meet the requirements of national standards. The following chapters will describe the Settings during the detection process in detail.

### **Features are as follows:**

1, built-in single 18650 large capacity lithium battery, power management module, in the use of the process to ensure stable power supply, low interference output; When the voltage is lower than 3.6V, the digital tube flashes, indicating low power; External 4.2V DC power charger.

2, External analog finger for easy connection to any blood oxygen detector.

3, Using the key to operate, you can directly change each data bit of the parameter, parameter change is simple, convenient, fast, convenient for users to set.

4, The 4-digit digital tube is used to display parameter items, such as blood oxygen saturation value, pulse rate value, signal strength, curve selection and other parameters.

5, The simulator is a transmission type blood oxygen optical simulator.

6, You can set the periodic automatic adjustment of blood oxygen saturation and pulse rate, and the automatic adjustment period can be set. When the period is set to zero, it means manual adjustment; It is used to customize the value change during production aging.

### **Blood oxygen part performance introduction:**

- External analog finger, can be easily connected to any blood oxygen test instrument;
- It is a transmission type multi-functional optical analog instrument, built-in commonly used BCI, Nellcor, Minary, Masimo four waveform curves;

- Blood oxygen saturation simulation range:
  - 80%, 85%, 90%, 98%, 4-point numerical detection and calibration, error  $\leq 1\%$ ;
  - 60%, 65%, 70%, 75%, 4-point numerical detection and calibration, error  $\leq 2\%$ ;
- Pulse rate simulation range:
  - 30bpm, 60bpm, 80bpm, 100bpm, 120bpm, 160bpm, 180bpm, 240bpm, a total of 8 test points, error  $\leq 1\text{bpm}$ ;
- Pulse intensity range:
  - 1%, 2%, 4%, 5%, 10%, 20%.

Note: Most of the blood oxygen products commonly produced by large manufacturers on the market use NELLCOR curve, a small number of BCI, Mindray series products please choose the corresponding Minary curve; Brand Monitor If the instrument is marked with the MASIMO logo, use the corresponding MASIMO curve. Since the product database does not necessarily cover all instruments at home and abroad, the blood oxygen of some instruments may not be detected or the detection value is different. Welcome to feedback to our company for product improvement and upgrading!

## Chapter 2 Precautions for SKX-1000D instrument use

- 1, Because the blood oxygen saturation detection needs to correspond to optical signals, when using this simulator, please try to avoid detection under strong light, which may cause numerical deviation, especially when digital blood oxygen detection, you can use some shading facilities to block light when necessary;
- 2, the analog finger of the analog instrument has positive and negative (or up and down) direction, only and must be in the correct direction of the premise, in order to carry out normal work;
- 3, When the digital tube flashes, it means that the built-in battery voltage is lower than 3.6V, please charge as soon as possible after this state, so as not to affect the normal use;
- 4, When using NELLCOR or Mindray Curve, you must choose a 660nm/905nm blood oxygen probe for easy consistency with clinical data. When using BCI curves, use a 660nm/940nm blood oxygen probe for easy consistency with clinical data. When selecting the MASIMO curve, use the MASIMO original probe.

## Chapter 3 SKX-1000D instrument connection description



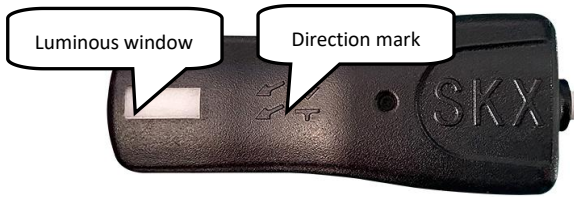

## Connection of blood oxygen probe to simulated finger:

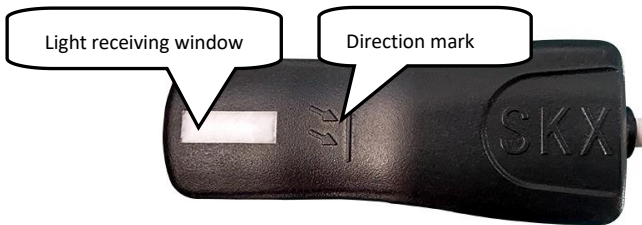

Place this side of the simulated finger (shown above) on the receiving tube end of the blood oxygen probe



Place this side of the simulated finger (shown above) on the red tube end of the blood oxygen probe

1. The part marked with  on the blood oxygen simulation finger, please point to the light-emitting tube part of the blood oxygen probe; Please point the part marked with  on the finger of the blood oxygen simulator at the receiving tube part of the blood oxygen probe. At the same time, be sure to note that the white window position on the finger should be aligned with the receiving tube position, otherwise the effective value may not be obtained.
2. When the blood oxygen probe is empty, the red light of the blood oxygen probe is blinking. When the simulated finger is placed in the blood oxygen probe, if it enters the normal working state, the red light of the blood oxygen probe is steady on.
3. In the process of detecting blood oxygen saturation, if there is a certain deviation in the blood oxygen value, you can check whether the value is corrected by repeatedly placing the analog finger.



## Chapter 4 Describes the SKX-1000D display contents

This simulator uses 4 digital tubes for display, each of which represents a different content, which will be described in detail below.



As shown in the figure above (1.98), there are four digital tubes from left to right, corresponding to the following contents:

1. The number 1 of the first digital tube is the menu item of waveform code, which represents the type of waveform issued by the current analog instrument. The specific type of waveform code is listed in the following table

Waveform code	Representative waveform
1	Blood oxygen saturation
2	Pulse rate value
3	Curve selection
4	Pulse intensity AMP
5	The value of blood oxygen saturation and pulse rate automatically adjusts the cycle

2. The second, third, and fourth digital tubes are numerical values representing specific parameters in the corresponding waveform menu item (corresponding to the hundreds, tens, and ones of the parameters, respectively).

For example:

When the value is 1.60, the current waveform is the blood oxygen waveform, and the blood oxygen value is 60%

When it is displayed as 1.98, the current waveform is the blood oxygen waveform, and the blood oxygen value is 98%

When it is displayed as 2.80, the current waveform is the blood oxygen waveform and the pulse rate value is 80bpm

## Chapter 5 SKX-1000D key description

There are four keys in this simulator, as shown in the figure below, they are shift select key, value increase key, value decrease key and confirm change key; The following describes the functions of the four buttons in detail.



As shown in the figure above, the current display content of the digital tube is 1.98, and there is a red decimal point in the lower right corner of the digital tube of the number 1, which represents the current number as the changeable item of the menu option;

**Shift selection key:** This key is used to select the content you want to change. If you want to change the type of waveform, please use this key to move the red decimal point to the first digit tube.

**Value increment key:** increase the numeric bit of the current change item;

**Value reduction key:** Reduce the value bit of the current change item;

**Confirm change key:** After the current change item is changed, please select this button to confirm the change;

## Chapter 6 Describes SKX-1000D parameter performance

The following describes the waveform parameters with waveform codes 1-5 and their Settings

### **1, blood oxygen saturation value:**

- ★ The blood oxygen value is set up in a total of 8 grades, which are 98%, 90%, 85%, 80%, 75%, 70%, 65%, 60%; Initial value: 98%;
- ★ The blood oxygen value can be directly selected and set through the key of value increase and value decrease, and there is no need to change the key by confirming.

### **2, pulse rate value:**

- ★ The pulse rate value is set in a total of 8 levels, which are 30bpm, 60bpm, 80bpm, 100bpm, 120bpm, 160bpm, 180bpm and 240bpm.
- ★ Error  $\leq 1$ bpm;
- ★ The initial value is 80bpm, and the blood oxygen value can be directly selected and set by the key of value increase and value decrease, and there is no need to change the key by confirming.

**3, Curve selection:**At present, a total of 4 curves are supported, respectively

- ★ Curve 1 is the BCI curve;
- ★ Curve 2 is NELLCOR;
- ★ Curve 3 is Mindray curve;
- ★ Curve 4 is the MASIMO curve.

### **4. Pulse intensity (AMP)**

- ★ Amplitude value: 20%, 10%, 5%, 4%, 2%, 1%, initial value 10%.

### **5, the value automatically changes the time cycle**

- ★ 0 indicates that the value is changed manually;
- ★ The value ranges from 1 to 60. The unit is minute;
- ★ When the value is set to automatic change, the value of blood oxygen saturation and pulse rate are changed in turn according to the set automatic cycle, and a total of 8 groups of data are changed in turn.

## Chapter 7 SKX-1000D after-sales service

\* The company will provide you with an 18-month warranty from the date of purchase of the instrument (battery, charger warranty for one year), the warranty expires, responsible for lifelong maintenance, and charge maintenance materials as required.

**\* Our company will not provide free warranty service for the following reasons:**

- Failure caused by disassembly and modification of the product without authorization.
- Analog finger damaged by external damage, no warranty is provided.
- Failure caused by careless falls and drops in the process of use and handling.
- Failure due to lack of proper maintenance and failure to meet environmental requirements.
- Failure caused by not following the correct instructions in the operating manual.
- Failure caused by self-repair without our company's permission.
- Failure caused by the irresistible forces of nature caused by natural disasters, fires, earthquakes, etc.

\* If you need warranty service, please contact our technical service center directly in the form of telephone, letter, fax, etc., such as contact with other personnel or departments, there may be information transmission interruption, resulting in misunderstanding of time and service, the most important thing is to affect your normal use.

\* After-sales service information:

- Full name: Xuzhou Mingsheng Electronic Technology Co., LTD
- Address: 726, Block A, Shimao Diamond International, Yunlong District, Xuzhou City
- ZIP Code: 221004
- Tel: 0516-83460606, 83469046
- Chuanzhen: 0516-83469046
- E-mail: xzFRD@163.com
- Company website: WWW.XZMSDZ.COM

# Appendix 1

## Weak perfusion characteristics of blood oxygen

Because the performance of digital oximetry mainly depends on the precision of digital probe, the performance of its receiving tube directly determines the weak perfusion performance of digital oximetry. Relative to the traditional analog signal method to get blood oxygen saturation, in a certain degree of weak perfusion, such as more than 1%, the performance of the digital probe is stronger than the analog probe, can improve anti-interference, mainly in no matter anyone's fingers thick or thin, children or newborns can get a good performance. When simulating blood oxygen in extreme fields such as newborn or children's fingers, if the fingers are very thin, the light transmittance of the fingers is too strong, which may cause misjudgment of the probe falling off detection. If the misjudgment is not caused, because the light transmission is too strong, it will lead to the front-end amplification part of the pulse detection circuit can not be simulated amplification, (because amplification will cause loss of pulse amplifier saturation state), so the waveform amplification function will be lost. In addition, because of the high light transmission intensity, although through adjusting the luminescence intensity of the luminescence tube, the received light intensity is still very strong. Therefore, in this state, the performance of analog blood oxygen is inferior to that of digital blood oxygen.

1. The digital oxygen receiving circuit has no limit on the light transmission intensity of the finger, so it improves the anti-interference ability in use and is suitable for a variety of people. However, the digital

receiving tube has the potential to cause AC signal saturation after too strong DC signal. When the DC component is too large, it will cause the AC signal to work in an irregular interval, so it is suggested that the digital reception should come with luminous brightness adjustment, for the digital receiving tube work in a most reasonable space.

2. because the weak perfusion performance of digital blood oxygen completely depends on the performance of the receiving tube, so for a certain digital receiving tube, its weak perfusion performance is also determined, restricting the weak perfusion can not be further improved, after testing its weak perfusion performance can only be around 1%, can not be further improved.

3. Because the analog probe uses multistage signal amplification, for example, the pulse signal can be amplified and reduced through the adjustment of luminous intensity first, the pulse signal can be amplified by amplifying the pulse carrier signal, and finally the pulse signal can be amplified by high-precision AD and other ways to collect the pulse signal. Through the above three ways, the weak perfusion performance of blood oxygen can be improved, far more than the weak perfusion performance of digital probe. However, the above method has special circumstances, such as newborns or children, because the finger is small and thin, will lead to the finger light intensity is very strong, may lead to the first two kinds of signal amplification part performance failure, if you can overcome the above problems, the weak perfusion performance of the analog probe is much stronger than the digital probe.

## About the detection method of simulated blood oxygen

The diode drive part can adjust the current through the diode to change the luminous intensity through the analog quantity "SPO2\_DRV"

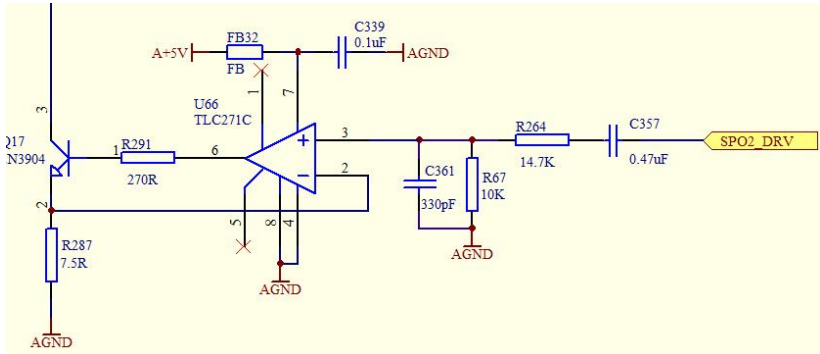

## Receiving tube part circuit

The waveform received by the differential amplification receiving tube is similar to the above luminous waveform, except that the blood oxygen waveform signal is already contained.

As the above waveform is similar, the blood oxygen waveform data has been contained, in this case, the waveform should be amplified according to the amplitude of the waveform, and finally enter the AD part of the CPU for direct acquisition, it is noted that there is no need to separate the above waveform, only need to be in the CPU program end according to the timing of the luminous part. It is OK to collect the waveform at the corresponding time point, and it is recommended that AD signals should be collected before closing and switching the light tube, so as to obtain effective data to the maximum extent.



The sequential circuit of the blood oxygen device driving the luminescent tube is shown below, with four modes:

1, red light, infrared light alternating, the pulse period is the same, the dark period and the luminous period are equal.

The luminescence period can be set to 200us-1ms. The Dash series Nellcor module uses a 500us luminescence cycle

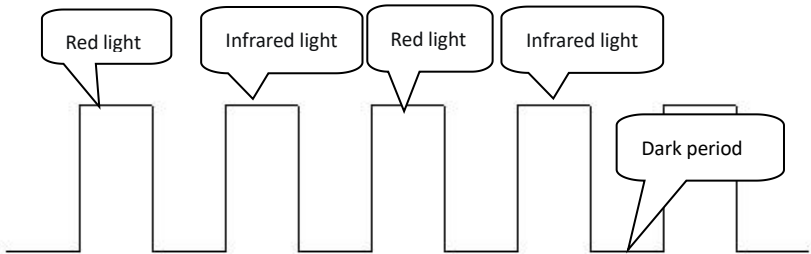

2, The timing of red and infrared light is fixed, as shown in the figure below:

The luminous order of red light and infrared light can be exchanged, but the cycle is the same cycle, the setting range is 200us-1ms, the dark period between red light and infrared light can be 200-1ms, and the fixed period between each group of luminous light can be customized according to demand, the default can be set to 8ms.

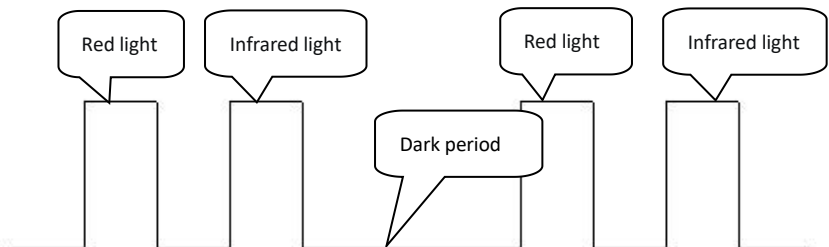

3, red and infrared light continuous light, no dark interval in the middle or dark interval is very small, less than 100us, as shown in the following figure:

In this case, the time interval of each group of luminous cycles is fixed, which can be defined as 8ms or other values

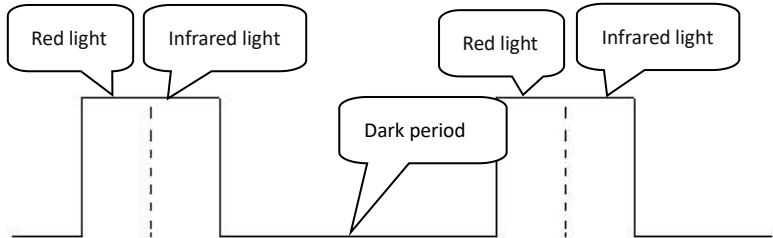

4, red and infrared light continuous light, no dark interval in the middle or dark interval is very small, less than 100us, as shown in the following figure:

In this case, the red and infrared light emission periods can be defined as 200us-1ms, and the time interval of each group of emission cycles is fixed, which can be defined as 8ms or other values

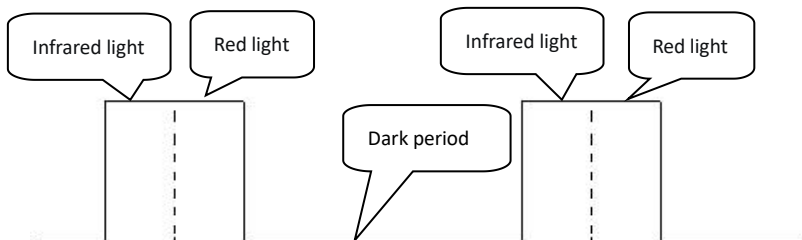

**Please note:**SKX-1000D blood oxygen simulator can detect the first three of the four cases. If the blood oxygen device is the fourth case of luminescence drive, please adjust the luminescence timing to meet the three cases.